

流延薄膜 生产线

SML
EXTRUSION LINES – ENGINEERED TO PERFORM ▶

▶ CPP/CPE和PET流延薄膜

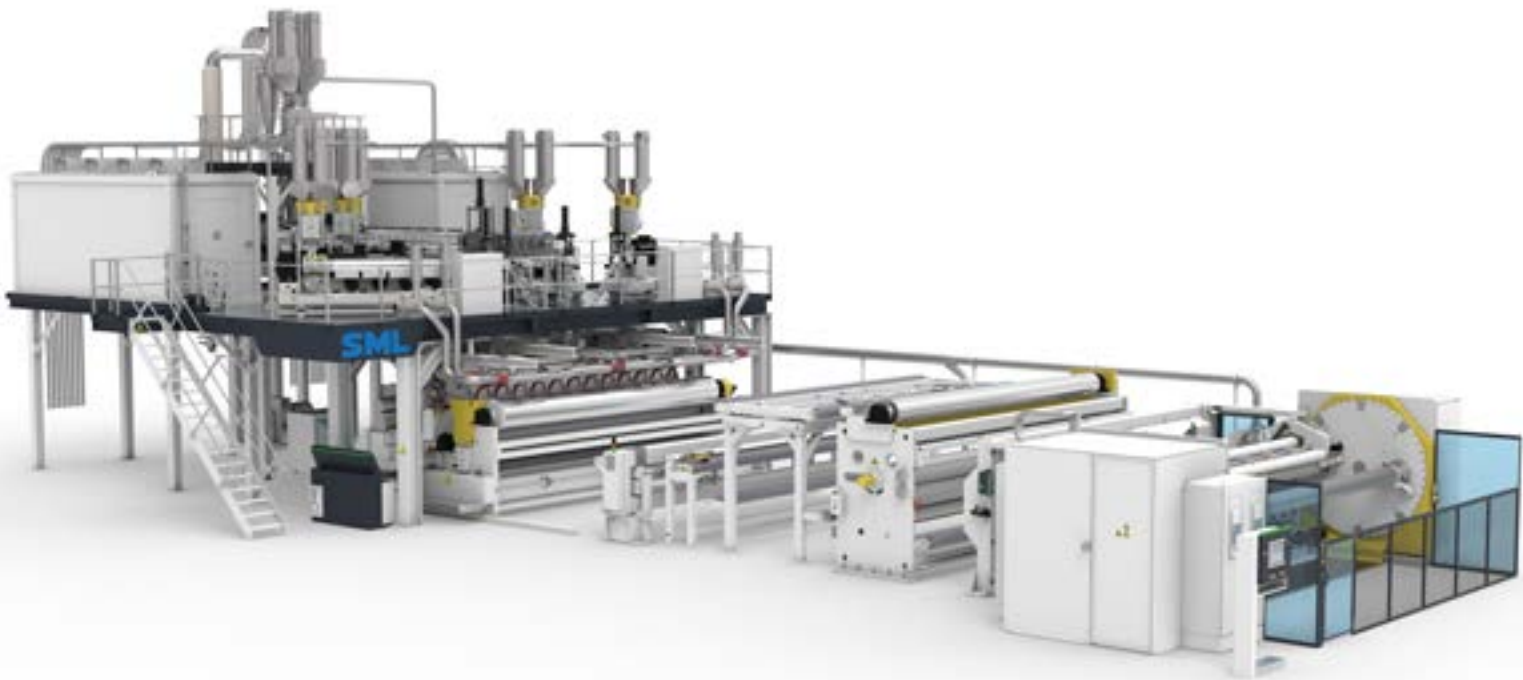

**Extrusion lines –
engineered to perform**

精确到最小细节

SML的流延薄膜生产线可生产光学性能优异的CPP、CPE和PET流延薄膜。SML能够满足所有客户的需求 — 从6.5米宽的XXL级工业生产规模生产线，到薄膜净宽1米的灵活窄幅生产线。整条生产线可按客户需求量身定制。

主要特点

- 生产透明和低雾度薄膜
- 产品厚度范围大
- 实现高产能的超宽生产线
- 满足个性化需求的多种收卷单元

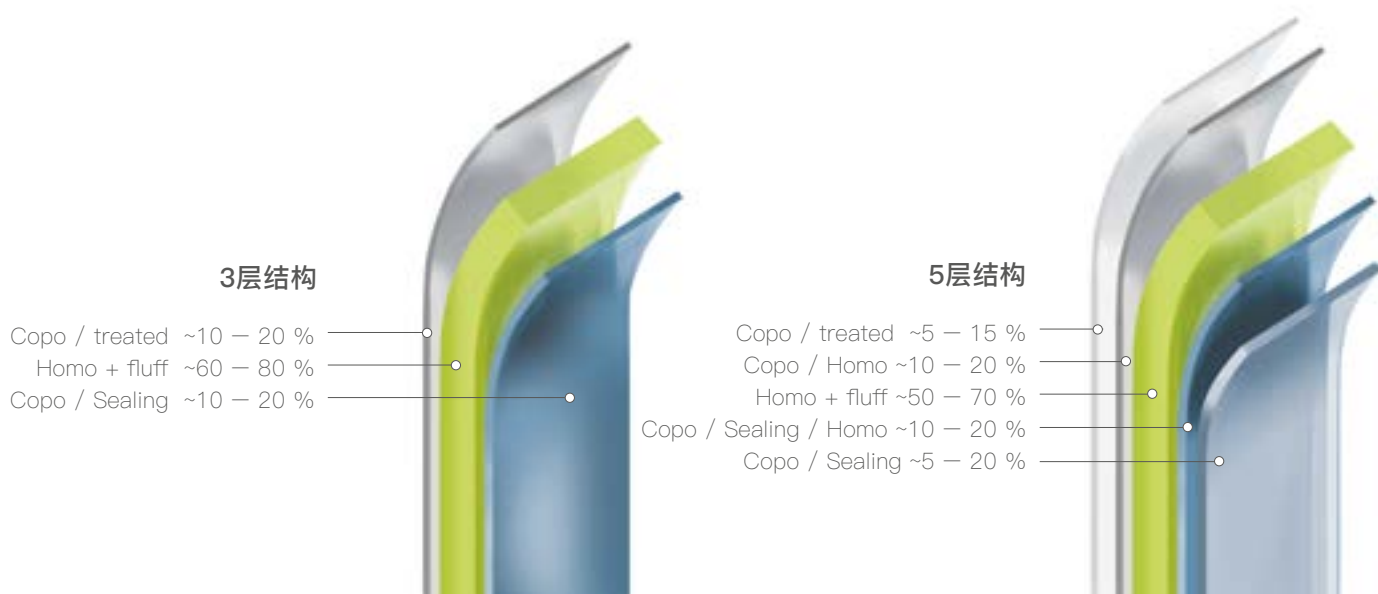

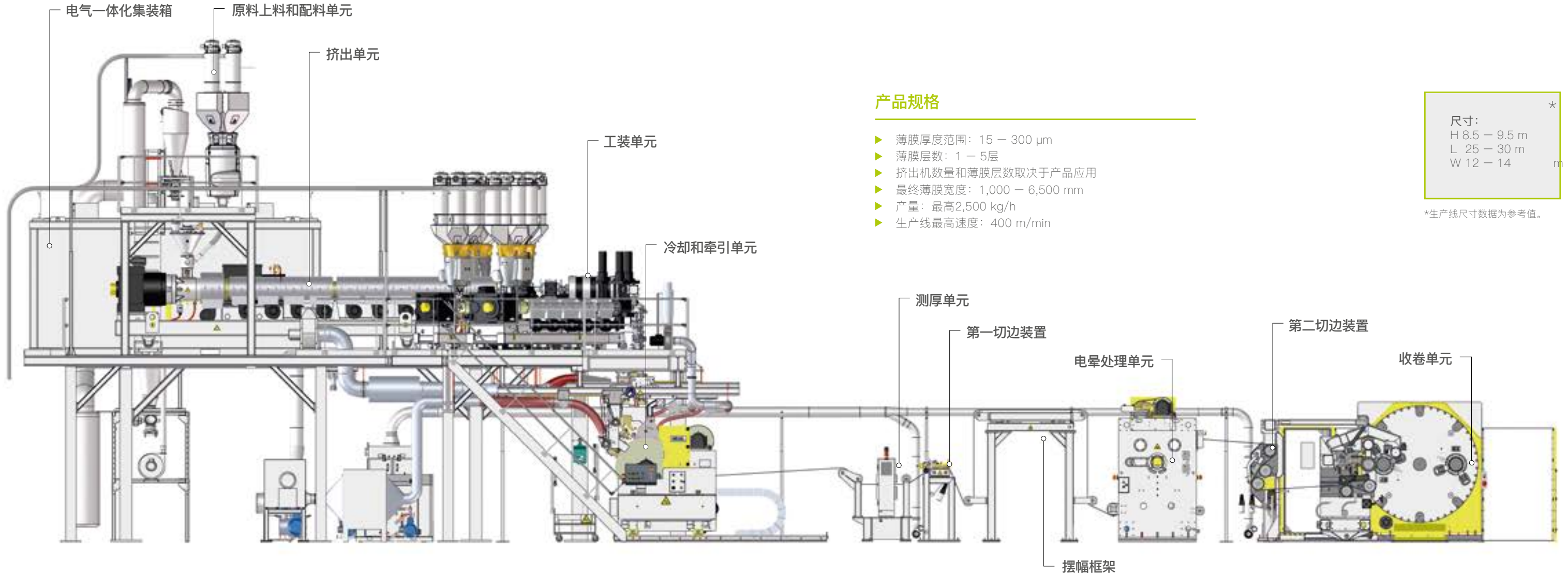

产品规格

- ▶ 薄膜厚度范围: 15 – 300 μm
- ▶ 薄膜层数: 1 – 5层
- ▶ 挤出机数量和薄膜层数取决于产品应用
- ▶ 最终薄膜宽度: 1,000 – 6,500 mm
- ▶ 产量: 最高2,500 kg/h
- ▶ 生产线最高速度: 400 m/min

尺寸:	*
H 8.5 – 9.5 m	
L 25 – 30 m	
W 12 – 14 m	

*生产线尺寸数据为参考值。

冷辊单元

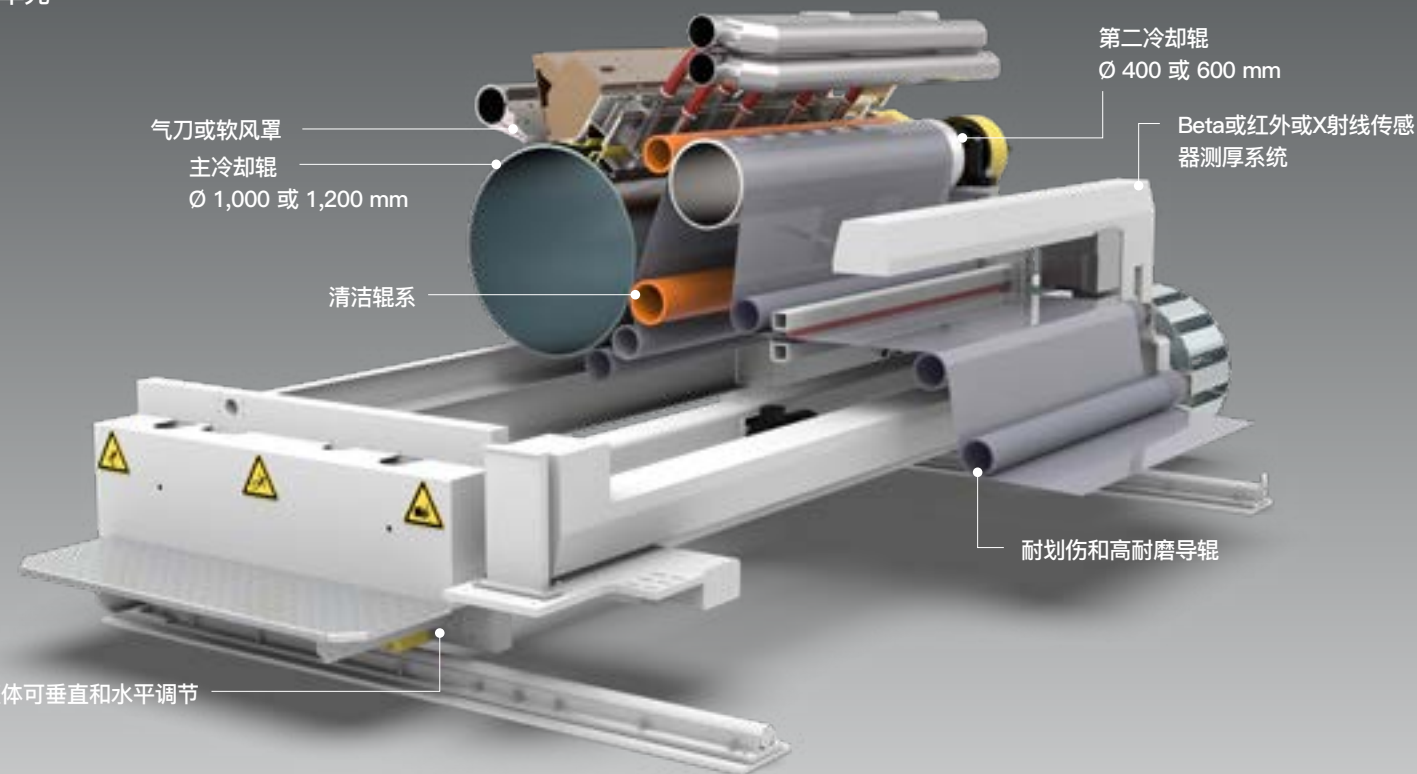

单元整体可垂直和水平调节

挤出单元

- ▶ 称重式配料单元
- ▶ 挤出机数量: 1 – 5台
- ▶ 挤出机直径: 60 – 180 mm / 可选装双螺杆挤出机
- ▶ 液压盘式或蚀式过滤器
- ▶ 固定式或可调式几何设计分流道
- ▶ 自动单腔或多歧管模头
- ▶ 模头分离系统
- ▶ 双腔真空吸气罩
- ▶ 主挤出机配有立式边条挤出机, 用于边条的再喂入

收卷单元

- ▶ 转塔式收卷机, 收卷最大直径达1,500 mm的母卷
- ▶ 卧式滑轨收卷机, 收卷在线分切膜卷和3英寸、6英寸母卷
- ▶ 根据薄膜产品提供不同的横切单元
- ▶ 可提供小膜卷生产解决方案

下游设备

- ▶ 电晕处理前的切边装置
- ▶ 单面、单面可切换或双面电晕处理单元
- ▶ 电晕处理后的后冷却辊
- ▶ 摆幅框架或收卷机摆动
- ▶ 薄膜质量检测系统



始终针对客户需求进行特别优化

流延薄膜产品主要应用于食品和消费品包装行业。由于流延薄膜具备的特殊性能，工业应用和医疗产品已成为新增的应用领域。



充分利用我们全球领先的挤出技术。

分析
开发
预测试性能
按时交付
服务支持
客户满意

SML
EXTRUSION LINES – ENGINEERED TO PERFORM ▶

SML - Head Office

Gewerbepark Ost 32
4846 Redlham
Austria
Phone: +43 7673 90999
E-mail: sml@sml.at
www.sml.at

SML - Machinery Far East Sdn Bhd

(1029958-P)
1201 Block B, Menara Amcorp
No.18 Jalan Persiaran Barat
46050 Petaling Jaya
Selangor Darul Ehsan,
Selangor, Malaysia
Phone: +60 3 7955 9098
E-mail: yen@sml.at

SML – 北京代表处

北京市朝阳区东三环北路8号
亮马河大厦1410室
邮编: 100004
电话: +86 10 6590 0946
邮箱: sml@sml.bj.cn

**SML - North America
Service, Inc.**

Suite 204
85 Eastern Avenue
Gloucester MA 01930
USA
Phone: +1 978 281 0560
Mobile: +1 978 394 1553
E-mail: jom@sml.at



www.sml.at